

⚠ ⚠ DANGER / DANGER / PELIGRO / GEFAHR / PERICOLO / PERIGO / 危險 / ОПАСНОСТЬ

<p>HAZARD OF ELECTRIC SHOCK, EXPLOSION, OR ARC FLASH Disconnect all power before servicing equipment Failure to follow these instructions will result in death or serious injury.</p>	<p>RISQUE D'ÉLECTROCUTION, D'EXPLOSION OU D'ARC ELECTRIQUE Coupez toutes les alimentations avant de travailler sur cet appareil. Le non-respect de ces instructions provoquera la mort ou des blessures graves.</p>	<p>PELIGRO DE DESCARGA ELÉCTRICA, EXPLOSIÓN O ARCO ELECTRICO Desconecte todas las alimentaciones antes de manipular el producto. Si no se siguen estas instrucciones provocará lesiones graves o incluso la muerte.</p>	<p>GEFAHR VON ELEKTRISCHEM SCHLAG, EXPLOSION ODER LICHTBOGEN Vor dem Arbeiten am Gerät alle Spannungsversorgungen abschalten. Die Nichtbeachtung dieser Anweisungen führt zu Tod oder schwereren Verletzungen.</p>
<p>RISCHIO DI SCARICA ELETTRICA, ESPLOSIONE O ARCO ELETTRICO Scollegare l'apparecchio da tutti i circuiti di alimentazione prima di qualsiasi intervento. Il mancato rispetto di queste istruzioni provocherà morte o gravi infortuni.</p>	<p>RISCO DE ELECTROCUSSÃO, DE EXPLOSIÃO, OU DE ARCO ELÉCTRICO Desconecte todas as alimentações antes de manipular o produto. A não observância destas instruções resultará em morte, ou ferimentos graves.</p>	<p>可能有触电、爆炸或者电弧灼伤的危险 在此电力设备上工作时 请先切断所有电源。 不遵循上述规定将可能导致人员伤亡。</p>	<p>ОПАСНОСТЬ ПОРАЖЕНИЕМ ЭЛЕКТРИЧЕСКИМ ТОКОМ, ОПАСНОСТЬ ВЗРЫВА ИЛИ ВСПЫШКИ ДУГИ. Перед обслуживанием или ремонтом убедитесь, что питание отключено. Несоблюдение этих инструкций при ведет к смерти или серьезной травме.</p>

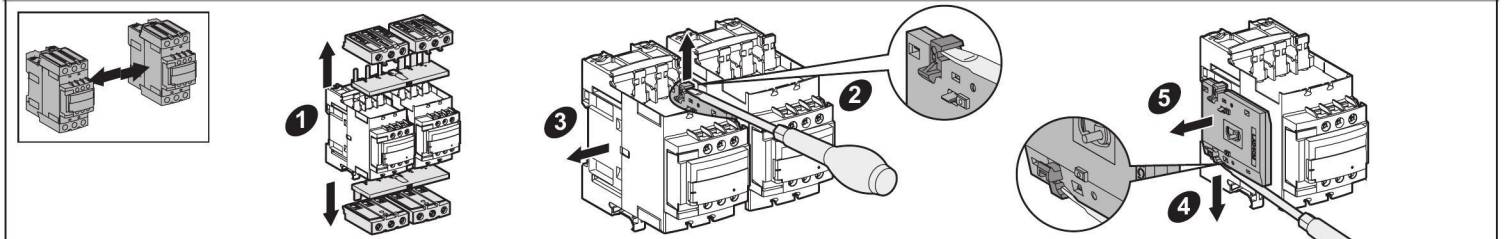
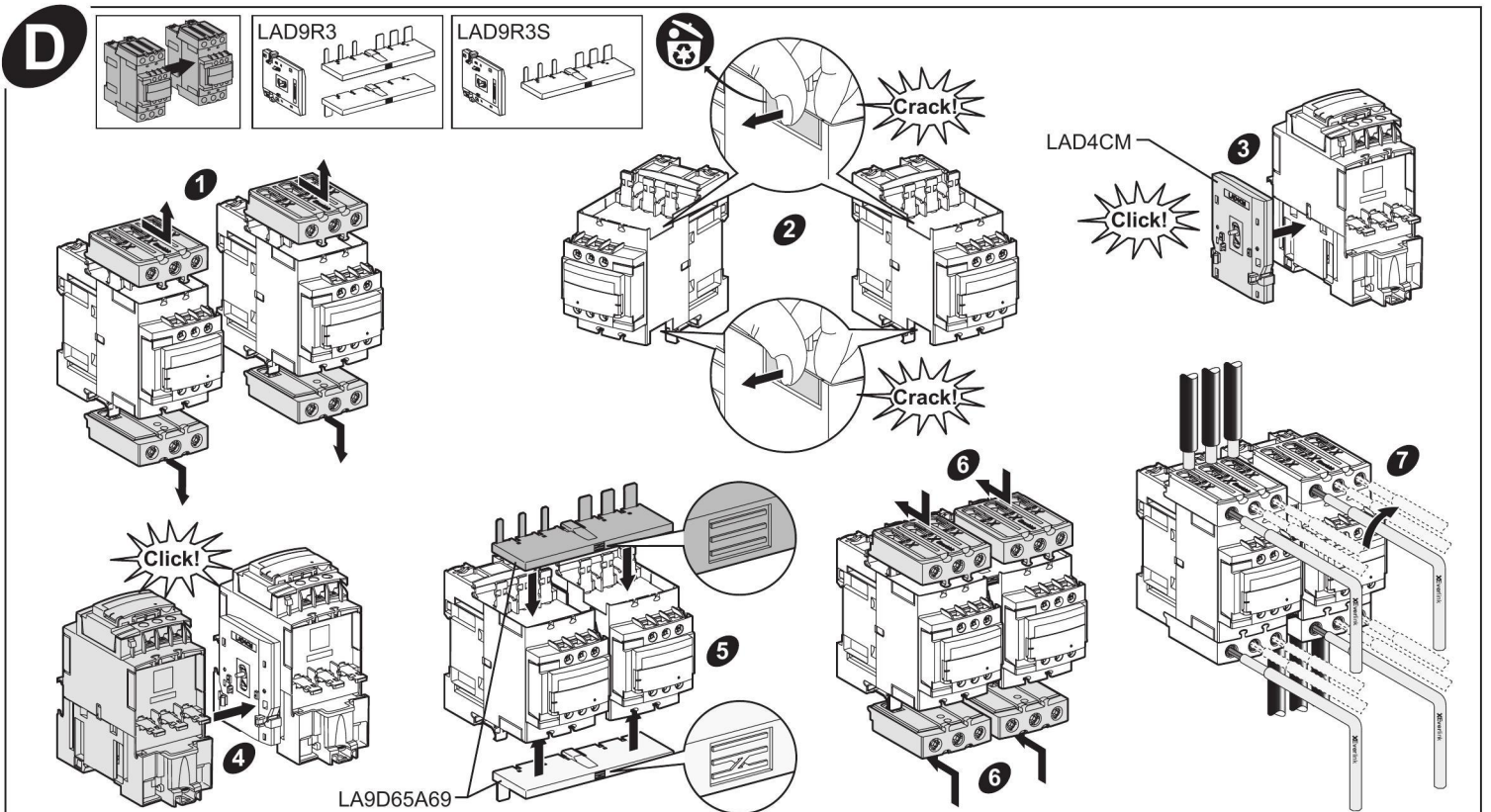
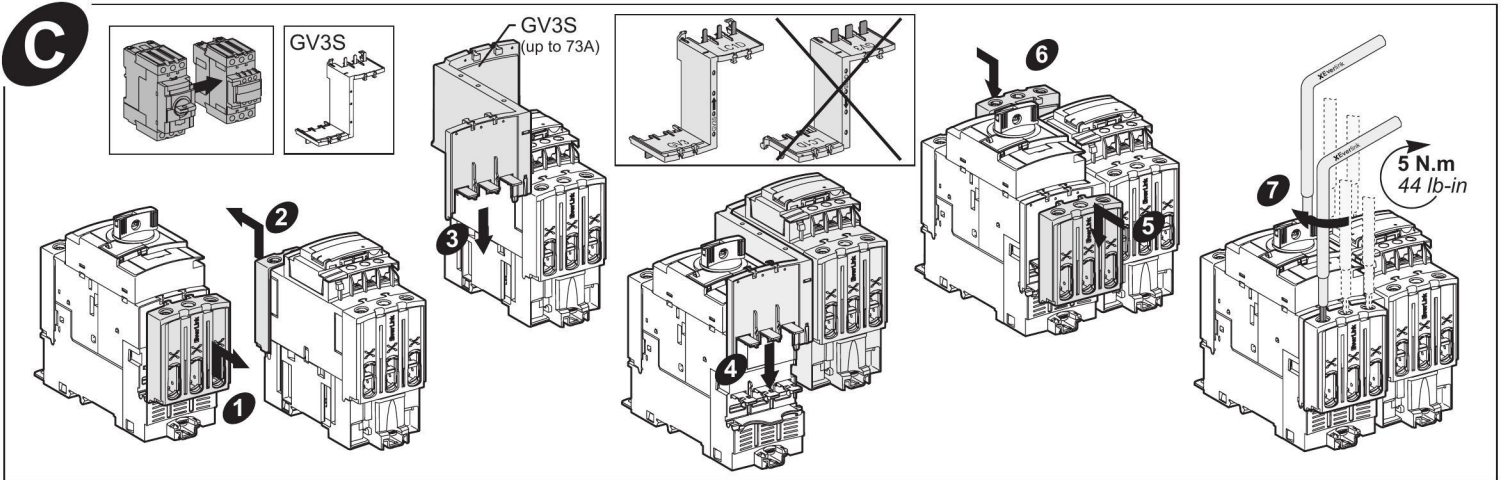
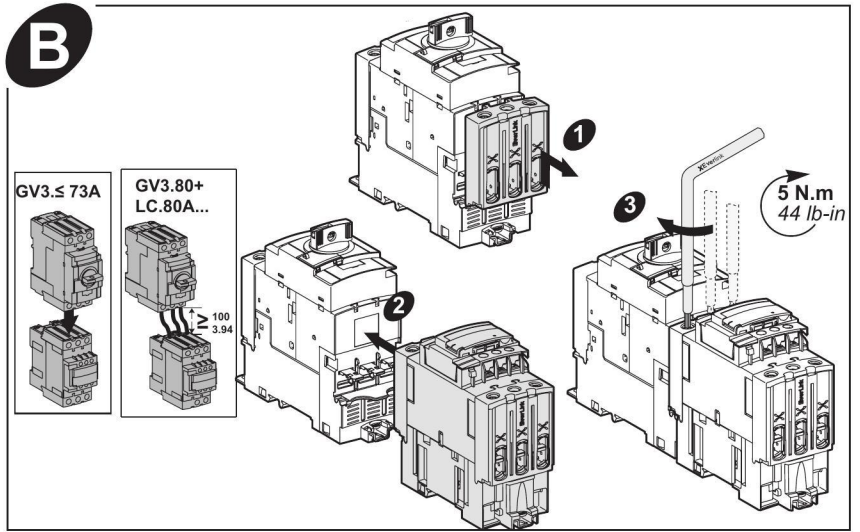
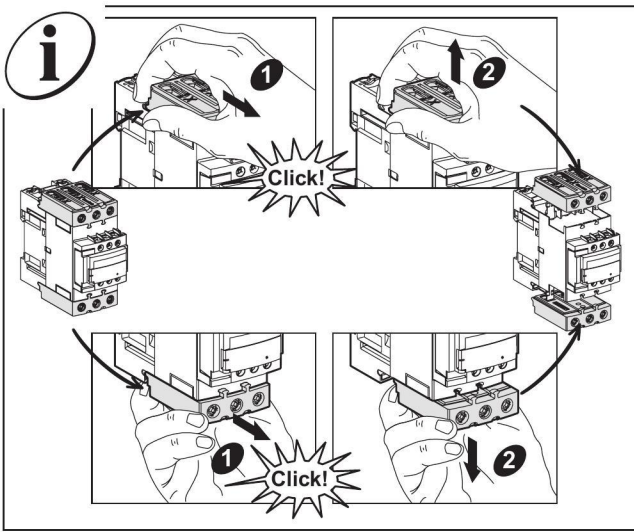

E

Rail 35 mm → EN 50022, NFC 63015

mm
in

In case of vibration above 3gn on contactor with electronic coil and direct mounting with LRD, it is recommended to mount the devices by screws on metal plate.

F

Rail 35 mm → EN 50022, NFC 63015

mm
in

GV3.≤ 73A

120⁺³
4.72^{+0.12}

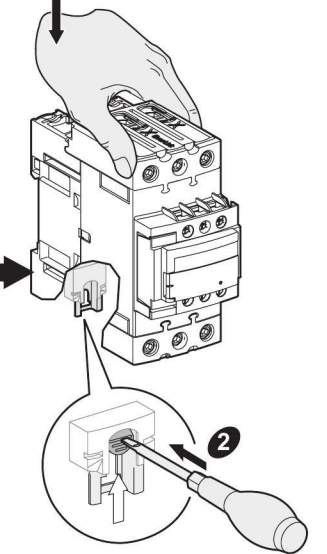
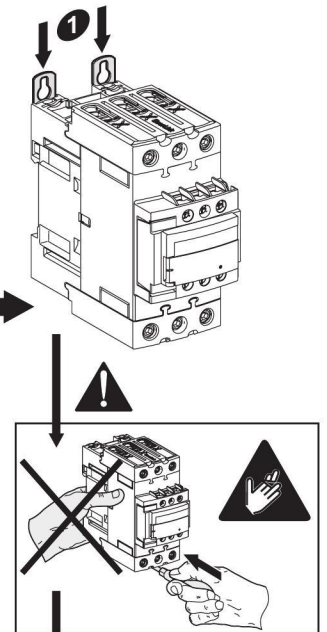
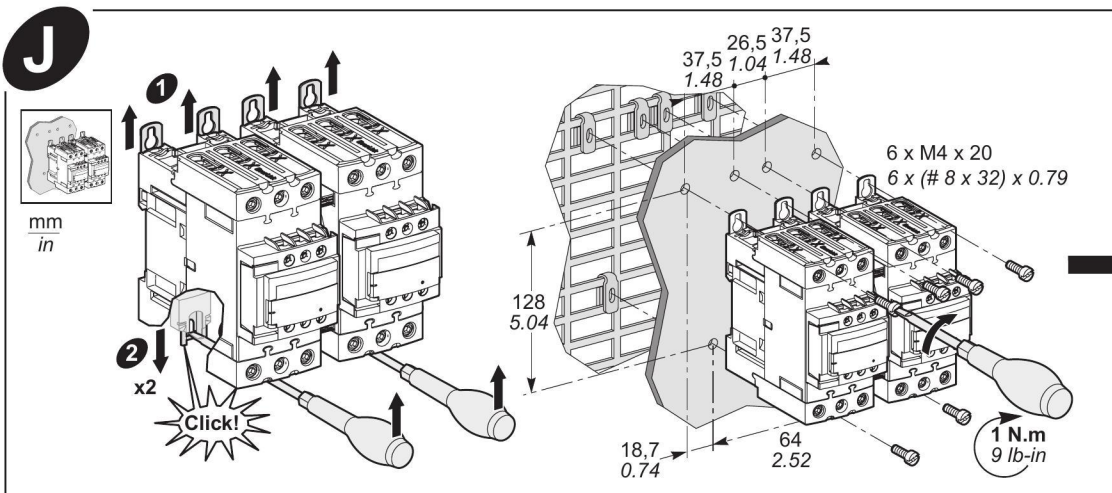
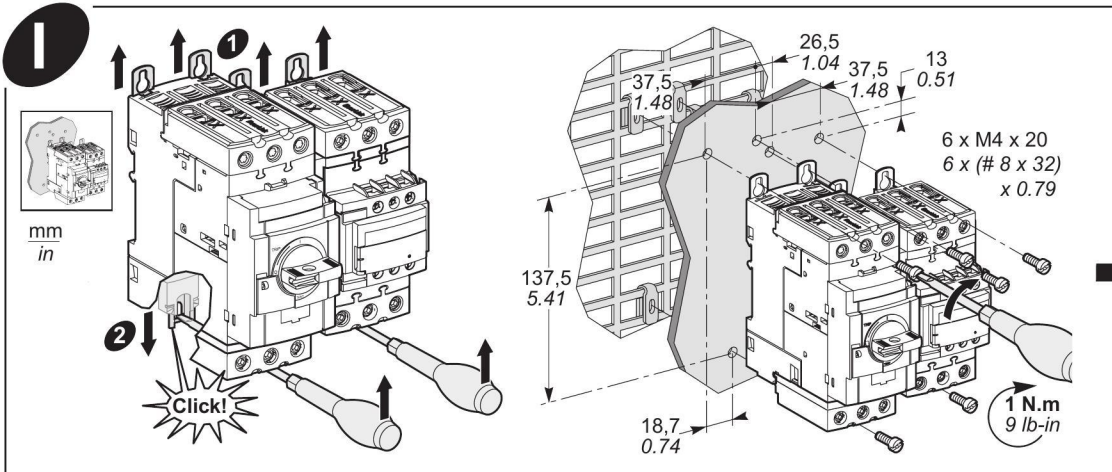
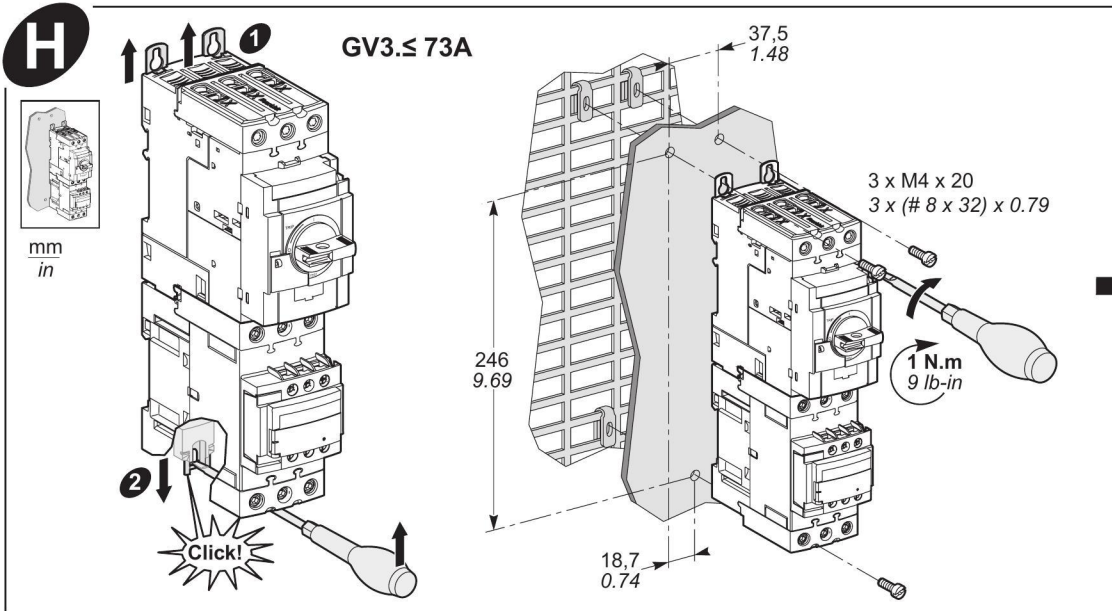
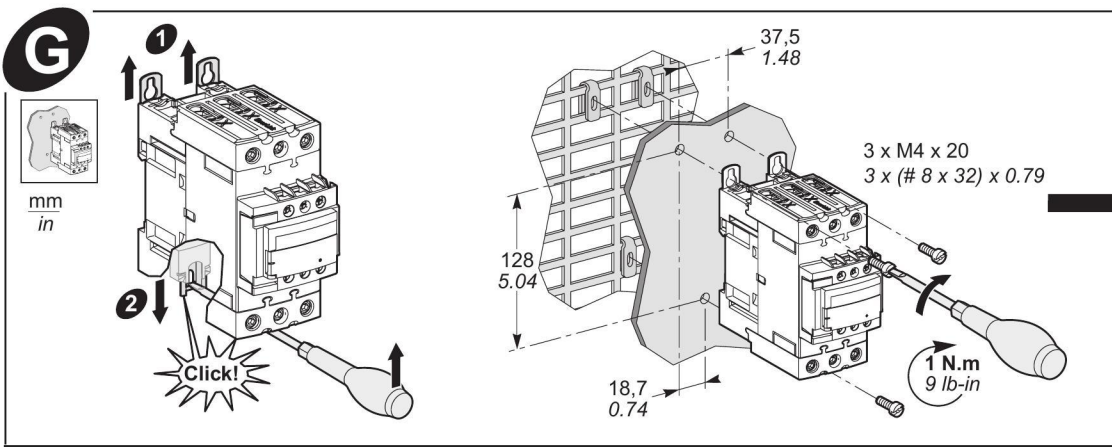

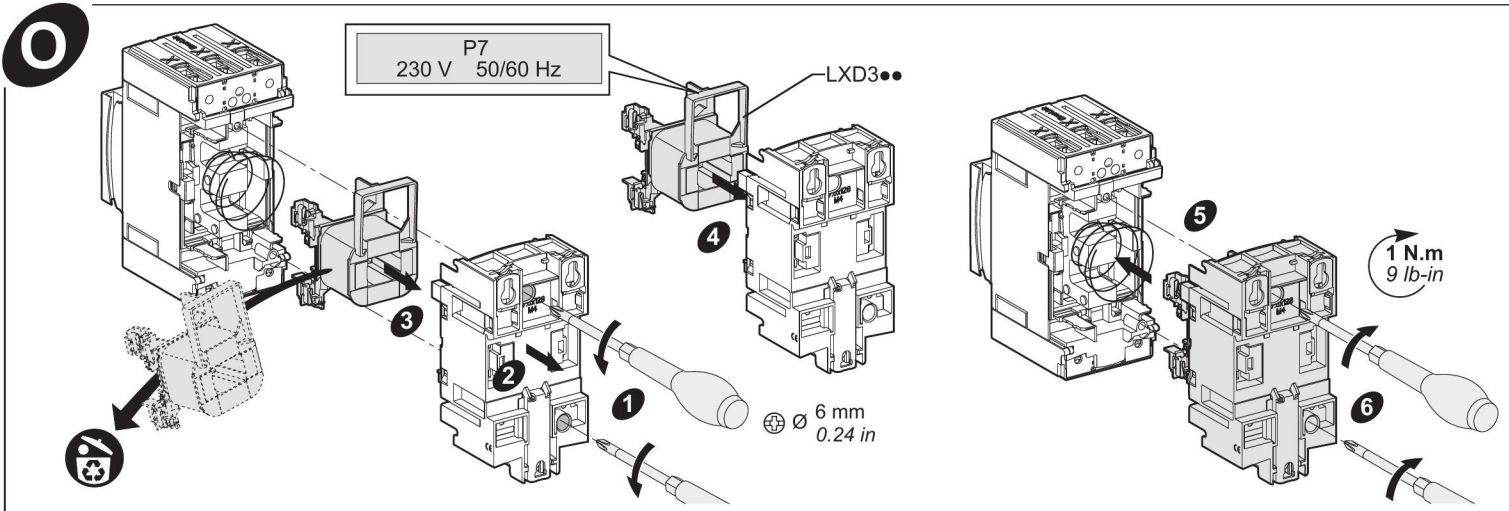
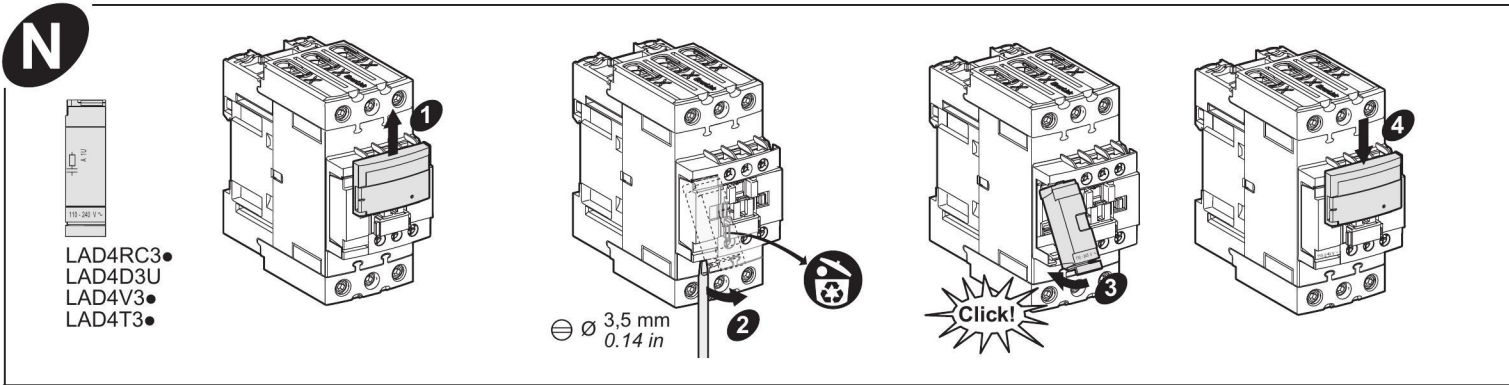
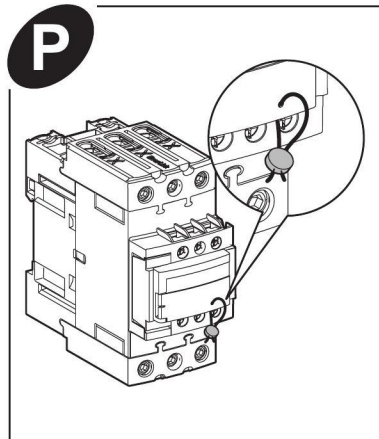
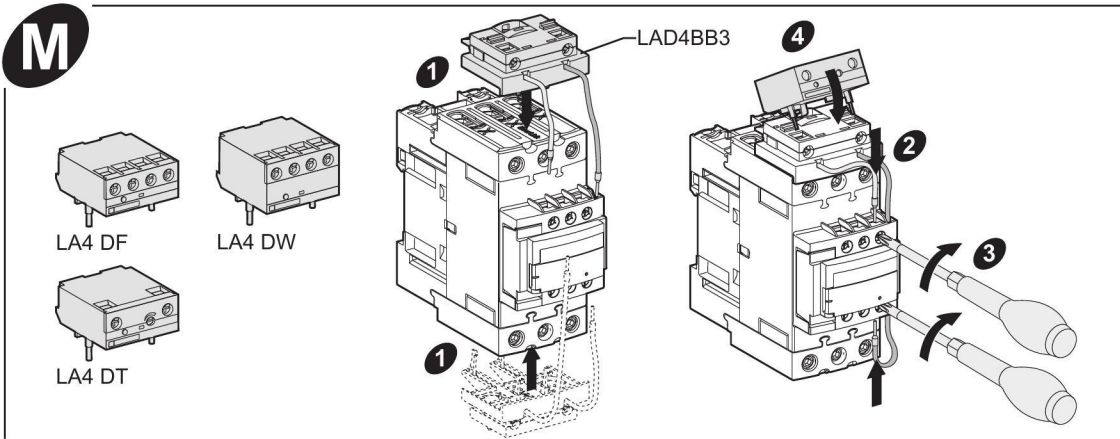
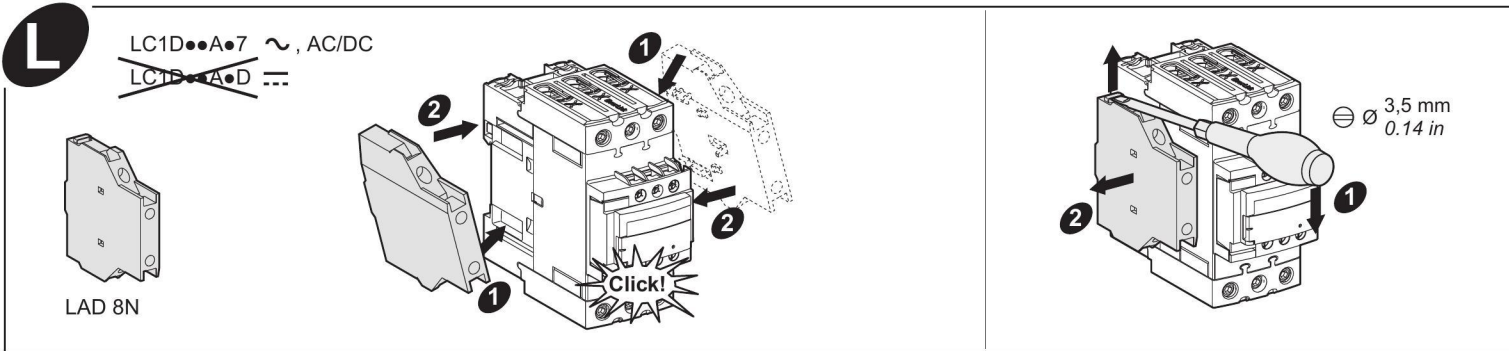
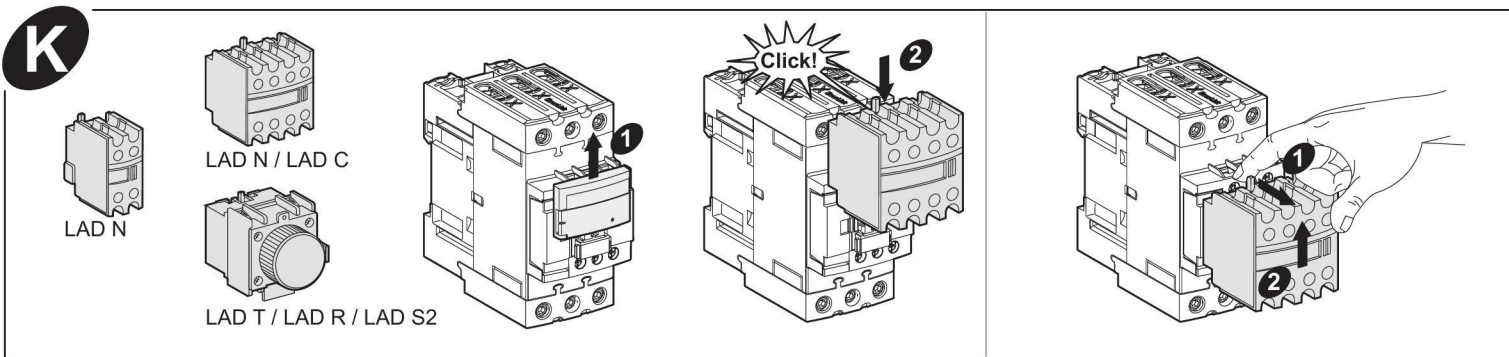

Q

LC1D●●A

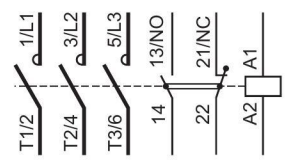
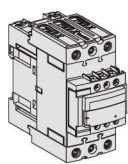

LC2D●●A

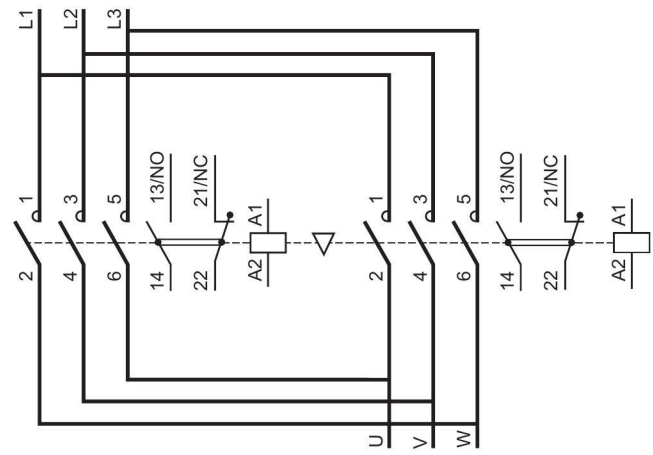
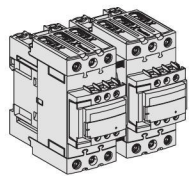

R

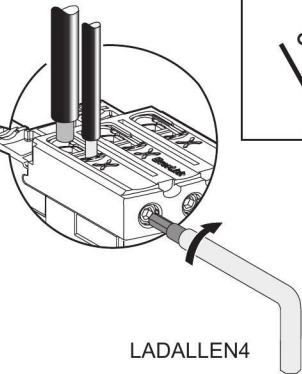
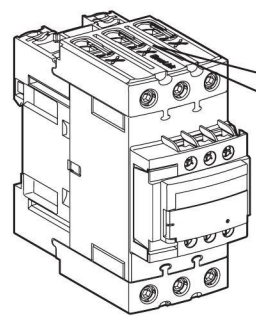

LADALLEN4

LC1D●●A LC2D●●A					
	16 mm	1...25 mm ²	2 x 1...25 mm ²	5 N.m	LADALLEN4
	16 mm	35 mm ²	1 x 1...25 mm ² + 1 x 35 mm ²	8 N.m	4 mm
	0.63 in.	AWG 16...2	1 x AWG 16...4 + 1 x AWG 16...2	70 lb-in	0.16 in

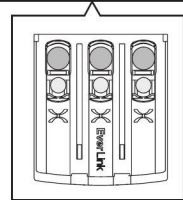

S

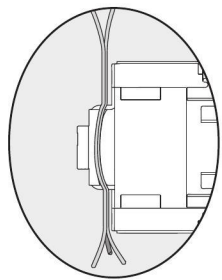
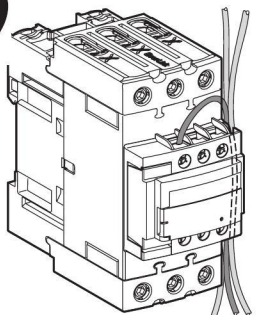

LC1D●●A LC2D●●A						
	10 mm	1...4 mm ²	1...2,5 mm ²	1,7 N.m	PH 2	
	0.4 in.	AWG 16...12	AWG 16...14	15 lb-in		

T

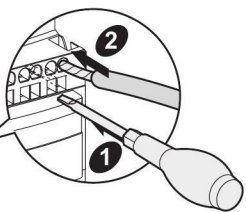
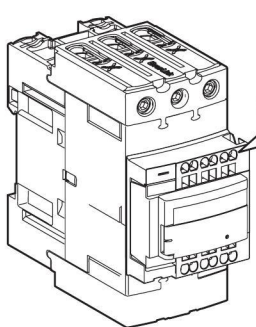

LC1D●●A3 LC2D●●A3		
	0,75...2,5 mm ²	Ø 3,5 mm
	AWG 20...12	0.14 in.

3P AC TeSys D contactors (LC1D40A ->LC1D80A) are grade 2 according to GB 21518. Maximum power consumption lower than 36.6 VA.

根据GB 21518标准，三极 TeSys D Everlink系列交流接触器 (LC1D40A -> LC1D80A) 能效等级为2级，产品最大吸持功率低于36.6 VA。

3-фазные контакторы переменного тока TeSys D (LC140A->LC1D80A) относятся к категории 2 согласно GB 21518. Максимальная потребляемая мощность ниже 36,6 ВА.

AC/DC: - use of this product in EMC environment B may require mitigation measures to avoid unwanted disturbance.
- full open AC at 10%Us

⚠️ ⚠️ WARNING / AVERTISSEMENT / ADVERTENCIA / WARNING / AVVERTENZA / ATENÇÃO / 警告 / ПРЕДУПРЕЖДЕНИЕ

RISK OF FIRE OR ELECTRIC SHOCK (FOR CONTACTOR WITH UL HI-FAULT SHORT CIRCUIT CURRENT RATINGS ONLY)
 ■ The opening of the branch-circuit protective device may be an indication that a fault current has been interrupted.
 ■ To reduce the risk of fire or electric shock, current-carrying parts and the other components of the controller should be examined and replaced if damaged.
Failure to follow these instructions can result in death, serious injury, or equipment damage.

RISQUE D'INCENDIE OU D'ELECTROCUTION (POUR LE CONTACTEUR AYANT DES COURANTS DE COURT-CIRCUIT ASSIGNES UL TRES ELEVES UNIQUEMENT)
 ■ L'ouverture du dispositif de protection du circuit de dérivation peut indiquer qu'un courant de défaut a été interrompu.
 ■ Pour réduire le risque d'incendie ou d'électrocution, les parties sous tension et les autres composants du contrôleur doivent être examinés et remplacés en cas de dommage.
Le non-respect de ces instructions peut provoquer la mort, des blessures graves ou des dommages matériels.

RIESGO DE INCENDIO O ELECTROCUCIÓN (SOLO PARA EL CONTACTOR CON CORRIENTES DE CORTOCIRCUITO ASIGNADAS UL MUY ELEVADAS)
 ■ La abertura del dispositivo de protección del circuito de derivación puede indicar que una corriente de fallo ha sido interrumpida.
 ■ Para reducir el riesgo de incendio o electrocución, las partes bajo tensión y los demás componentes del circuito deben ser examinados y sustituidos en caso de dañarse.
Si no se siguen estas instrucciones pueden producirse lesiones personales graves o mortales o daños en el equipo.

BRAND- ODER STROMSCHLAGGEFAHR (NUR BEI SCHALTERN MIT KURZSCHLUSSFESTIGKEIT BEI HOHEM FEHLERSTROM NACH UL-STANDARD)
 ■ Das Öffnen der Schutzvorrichtung des Zweigstromkreises kann ein Hinweis darauf sein, dass ein Fehlerstrom unterbrochen wurde.
 ■ Um die Brand- oder Stromschlaggefahr zu mindern, sollten stromführende Bauteile sowie die anderen Komponenten des Steuergeräts überprüft und bei Beschädigung ausgetauscht werden.
Die Nichtbeachtung dieser Anweisungen kann Tod, schwere Verletzungen oder Sachschäden zur Folge haben.

RISCHIO DI INCENDIO O SCARICA ELETTRICA (SOLO PER CONTATTORE CERTIFICATO UL CON SCCL AD ALTA CORRENTE DI GUASTO)
 ■ L'apertura del dispositivo di protezione del circuito derivato può indicare un'interruzione della corrente di guasto.
 ■ Per ridurre il rischio di incendio o scarica elettrica, è necessario esaminare le parti in cui al momento passa la corrente e gli altri componenti del controllore e sostituirli se sono danneggiati.
Il mancato rispetto di queste istruzioni può provocare morte, gravi infortuni o danni alle apparecchiature.

RISCO DE INCÊNDIO OU ELETROCUSÃO (PARA CONTADORES COM ALTO VALOR NOMINAL DE CORRENTE DE CURTO-CIRCUITO DE FALTA UNICAMENTE)
 ■ A abertura do dispositivo de proteção do circuito derivado pode ser uma indicação de que uma corrente de falta foi interrompida.
 ■ Para reduzir o risco de incêndio ou eletrocussão, as partes condutoras de corrente e os outros componentes do controlador devem ser examinados e substituídos se estiverem deteriorados.
A não observância destas instruções pode provocar a morte, ferimentos graves, ou danos no equipamento.

有火灾或电弧灼伤危险 (仅当继电器发生超故障短路电流时)
 ■ 分支电流保护装置断开可能表明某故障电流已被切断。
 ■ 为减少火灾或电弧灼伤的危险, 应经常检查和更换 (如损坏) 控制器的带电部分及其它部件。
 不遵循上述说明可能导致人员伤亡或设备损坏。

ОПАСНОСТЬ ВОЗНИКНОВЕНИЯ ПОЖАРА ИЛИ УДАРА ЭЛЕКТРИЧЕСКИМ ТОКОМ (ТОЛЬКО ДЛЯ КОНТАКТОРОВ С ВЫСОКИМ НОМИНАЛОМ ТОКА КОРОТКОГО ЗАМЫКАНИЯ СОГЛАСНО UL)
 ■ Срабатывание расцепителя устройства защитного отключения групповой цепи может являться признаком наличия тока утечки.
 ■ Для снижения риска возникновения пожара или поражения электрическим током токоведущие части и другие детали контроллера следует регулярно проверять и заменять в случае повреждения.
 Несоблюдение этих инструкций может привести к смерти, серьезной травме или повреждению оборудования.

Additional ratings	Lighting Tungsten	Lighting Ballast	Definite Purpose ratings, 3 Phase, Load wiring: breaking all lines				Elevator Duty HP ratings (except .D and .W DC coil)						High-Fault SCCR Class J Fuse	High-Fault SCCR with CB	
			LRA			1Ph 120 V	1Ph 240 V	3ph 200 V	3ph 230 V	3ph 480 V	3ph 600 V	480 V		600 V	
Device	600 V	600 V	FLA	240 V	480 V	600 V	120 V	240 V	200 V	230 V	480 V	600 V	600 V	480 V	600 V
LC1D40A	60 A	60 A	40 A	240 A	200 A	160 A	-	5hp	10hp	10hp	-	-	100 kA	100 kA	50 kA
LC1D50A	70 A	70 A	50 A	300 A	250 A	200 A	3hp*	7.5hp	15hp	15hp	25hp*	30hp*	100 kA	100 kA	50 kA
LC1D50ANR●	-	-	-	-	-	-	-	-	-	-	-	-	100 kA	100 kA	50 kA
LC1D65A/80A	70 A	80 A	65 A**	390 A	325 A	208 A	3hp*	10hp*	15hp*	20hp*	25hp*	30hp*	100 kA	100 kA	50 kA

(*) Ratings certified by CSA
 Only applicable for UL/CSA marked products.

(**) 52A at 600V

Refer to information on device label when ordering replacement parts.	En cas de substitution, vérifier les caractéristiques électriques sur l'étiquette du produit.	En caso de reemplazo, verificar las características eléctricas en la etiqueta del producto.	For Ersatz elektrische Leistungstaden auf dem Typenschild überprüfen.
In caso di sostituzione verificare le caratteristiche elettriche riportate sull'etichetta.	Em caso de substituição verificar as características eléctricas na etiqueta do produto.	进行更换时, 产品标签上的电气特性需要检查核对。	В случае замены электрических компонентов должна быть проверена маркировка продукта.

<p>The product's manufacture date is coded PYYWWD, where:</p> <ul style="list-style-type: none"> PP: plant code YY: year of manufacture WW: week of manufacture (D: weekday of manufacture (Monday = 1)) 	<p>La date de fabrication du produit est codée PYYWWD, avec :</p> <ul style="list-style-type: none"> PP: code usine YY: année de fabrication WW: semaine de fabrication (D: jour de fabrication dans la semaine (lundi = 1)) 	<p>La fecha de fabricación del producto está codificada PYYWWD, donde:</p> <ul style="list-style-type: none"> PP: código de la planta YY: año de fabricación WW: semana de fabricación (D: día de la semana de fabricación (lunes = 1)) 	<p>Das Herstellungsdatum des Produkts ist folgendermaßen codiert: PYYWWD. Wobei:</p> <ul style="list-style-type: none"> PP: Werkscode YY: Herstellungsjahr WW: Herstellungswoche (D: Herstellungstag (Montag = 1))
<p>La data di fabbricazione del prodotto è indicata con il codice PYYWWD, dove:</p> <ul style="list-style-type: none"> PP: codice stabilimento YY: anno di fabbricazione WW: settimana di fabbricazione (D: giorno della settimana in cui il prodotto è stato fabbricato (lunedì = 1)) 	<p>A data de fabrico do produto está sob a forma de código PYYWWD, onde:</p> <ul style="list-style-type: none"> PP: código da fábrica YY: ano de fabrico WW: semana de fabrico (D: dia da semana de fabrico (Segunda-feira = 1)) 	<p>Дата производства продукта закодирована в формате PYYWWD, где:</p> <ul style="list-style-type: none"> PP: код завода YY: год производства WW: неделя производства (D: день недели, когда был произведен продукт (понедельник = 1)) 	<p>产品制造日期采用如下代码 PYYWWD, 其中:</p> <ul style="list-style-type: none"> PP: 工厂代码 YY: 制造年份 WW: 第几周制造 (D: 星期几制造 (星期一 = 1))



Schneider Electric Industries SAS
35, rue Joseph Monier - CS 30323
F - 92506 Rueil Malmaison Cedex
www.schneider-electric.com/contact

Уполномоченный
поставщик в РФ: АО "Шнейдер Электрик"
Адрес:
127018, г. Москва, ул. Двинцев, д.12, корп.1,
тел. +7 (495)777 99 88,
факс: +7 (495)777 99 94, 8-800-200-6446
www.schneider-electric.ru



Only for models bearing these marks